

FX1616-BA PLC

F-series : Ethernet, Modbus TCP/IP, Stepper Motor Drive, +Analog I/O, LCD port, RS232, RS485, Floating Pt, TRiLOGI Ladder+Basic

Product Description

The FX1616-BA PLC replaces the F1616-BA and includes a floating point processing feature. It is powered by Triangle Research's newest Smart TILE (TRi Integrated Logic Engine) brainboard. Though capable as a full-function, general purpose industrial PLC, the "BA" in its part number suggests extension of its application suitability into "Building Automation". The FX1616-BA is the ideal choice for controlling "Smart Buildings", whether it is to provide creature comfort for its occupants, or more importantly in today's world, to monitor and control the energy consumption in buildings and homes to eliminate waste.

Starting with the control I/Os, the FX1616-BA has built-in 32 digital I/Os (expandable to 256) that interface directly to 24VAC or DC power, 8 analog inputs and 4 analog outputs that are 0 to 10V range. Among the I/Os are 4 DC outputs that can also be used as PWM or AC phase control (light dimmer type) outputs, or to drive stepper motor(s). Also, there are 3 high-speed encoder inputs, 6 incoming pulse frequency counter inputs, as well as a built-in Infrared remote control interface. Unlike other PLC makes, these incredible features come in the STANDARD package at no additional cost to the buyer/user.

More importantly, the FX1616-BA's immense communication capability allows it to be used either as the master controller of a simple project such as in home automation, or as one of hundreds of "node controllers" in a complex building project. The built-in Ethernet port on the FX1616-BA PLC hosts both a PLC web server and a Modbus/TCP server, allowing up to 6 simultaneous connections with devices such as touch panel HMIs, hardware running SCADA and PC software or other node controllers. The controller is also able to send out emails to report real time events or check a specified website to retrieve dynamic contents. More standard interfaces on the PLC include one RS232 port and two RS485 ports, all of which support industry standard MODBUS RTU or ASCII protocols. A special set of interface pins is even provided on the PLC to allow addition of a third-party radio module known as XBEE which in turn enables this controller to interface to futuristic ZIGBEE wireless sensors and control modules.

Just as notable is Triangle Research's proven i-TRiLOGI "Ladder+BASIC" programming software which makes complex programming of the F-Series PLCs a whole lot easier than with standard ladder-logic programming. This great little controller is packaged to be ready immediately to interface to power meters, HVAC sensors, and/or talk to other other controllers to carry out sophisticated control tasks in a commercial building project.

Some Building Automation applications for this PLC include roles as Main HVAC controller, Slave HVAC controller for VAV or CAV boxes, lighting control and Audio-Video (AV) equipment control (learn and send 38KHz IR remote signal).

Pricing is multi-tiered with progressively attractive discounts depending on OEM order quantity. Like all Triangle Research Intl's PLCs, the F-series PLC price-to-performance profile is quite possibly the best in its class in the market.

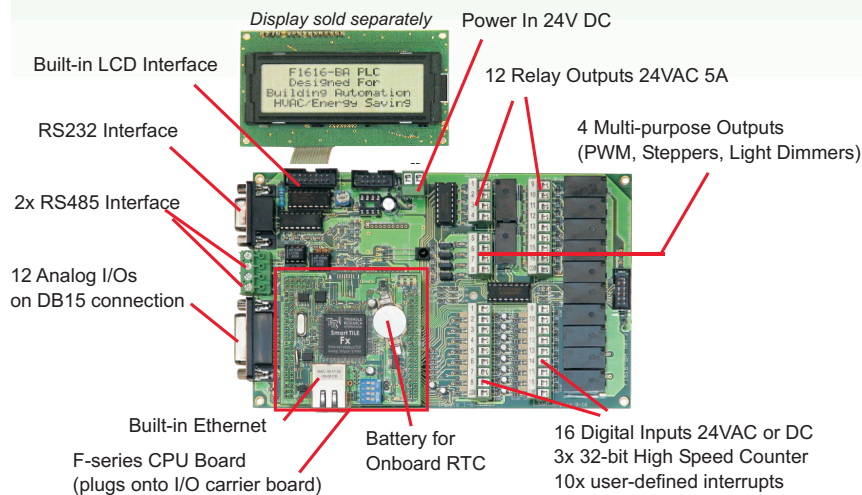

Mounting

(a) Hole mounting locations for direct panel mount

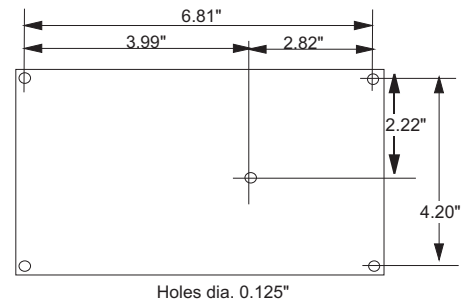

(b) Optional Din-Rail mounting kit available for installation on din-rails

Accessories Available :

- MMI8050iE (4.3") and MMI6070iE (7") Touchpanel COlor Display
- FP4030MR 3.1"HMI with 18 Push-Buttons
- LCD Displays : LCD216 (2 lines x 16 char.), LCD420 (4 lines x 20 char.)
- Networked Display : MDS100-BW for multiple displays application or for extended mounting of display
- MD-HMI : 16-key pad with 8 LED and 4x20 LCD; plugs into LCD and expansion ports
- I/O Expansion : Exp4040 or Exp1616R (16 Opto-isolated Digital Inouts, 16 Relay Outputs)
- Auto485 : RS232 to RS485 converter
- Analog Expansion : I-7000 series Analog I/O Expansion Modules
- USB-RS232 Interface : for connection to USB port on PC
- Din Rail Mounting : Din-Kit-2

Power Supply	24V DC (Regulated to ± 10%), 2A or more		
Digital Inputs (16)	#1 to #6	24VAC or 24VDC, NPN or PNP connection. NO FILTER (allow high speed encoder inputs)	
	#7 to #16	24VAC or 24VDC, NPN or PNP connection. Low Pass Filter accepts 50Hz presense as ON.	
	Encoder Inputs	- 3 x 32-bit High Speed Counter (quadrature: 2 D/Is per channel)	
	Interrupts	- 10 x user-defined interrupt (latency < 0.5ms, +ve or -ve edge triggered)	
Digital Outputs (16)	#5 to #8	ON/OFF	24VDC - Sink 4A continuous current. Driver Type : N-Channel power MOSFET.
		PWM	4 x PWM. Sink 8A max @24VDC. Variable frequencies. 0.1% duty cycle resolution
		Light-dimmer	Control the AC firing angle of up to 4 external TRIAC or SSR.
	#1 to #4 #9 to #16	Voltage-free RELAYs. Contact current = 5A @30VDC/120VAC or 2A @230VAC	
	Stepper Motor Control	- 2 x stepper motor control pulse/direction outputs (2 D/Os per stepper controller) or 1 x unipolar stepper motor DRIVER outputs (4 D/Os per stepper driver).	
Analog I/Os (8AI, 4AO)	- Input Interface	8 ch, 12 bit, 0-10V, 40KΩ input impedance	
	- Output Interface	4 ch, 10 bit, 0-10V, I _{source} = 20mA per output.	
Processing	I/O Scan time = 0.5ms (can be interrupted by input interrupts), Program Scan time = 2us per step		
High-Speed Counter	3x high-speed counters, 6x pulse measurement channels (frequency, period and width) - simultaneous position and speed measurement on each channel.		
Counters	64		
Internal Relays / Timers	512 internal relays, 64 timers (any one or all can be configured as "HighSpeed" timers)		
Sequencers	8 with 32 steps (step# 0 - # 31)		
Real-Time Clock	Real Time Clock and Calendar (Year, Day, Month, Hours, Min, Sec, day-of-week) - Lithium CR1632 battery-backed (runs up to 5 years without ext.l power or 10 years if powered off only 1/2 of the time) - Real Time Clock can be updated with Atomic clock data from NIST time server if PLC is connected to the Internet		
PID	Built-in 16 channels PID Computation function (Proportional, Integral, Derviative digital control)		
Connection Ports	- RS232	1 (DB9 female connector , DCE)	
	- RS485	2 x (two-pin screw terminals)	
	- Ethernet	1 RJ45	
	- LCD	1 (IDC 14-pin)	
	- I/O Expansion	1 (IDC 10-pin)	
	- Infra Red Remote Control	1 (38 KHz carrier) IR Remote control sensor. May be used as contactless data entry. Learn IR remote commands of AV and HVAC and regen. with IR LEDs (not included)	
	- Others	1x 2-pin screw terminal for DC power, 1 x 10-pin IDC header (reserved).	
Communications	Ethernet	- Direct connection to LAN or Internet for programming, monitoring and Remote Control - Support both Modbus/TCP Server (5 simult. connections) and Modbus/TCP Client - Extremely easy Peer-to-peer (or machine-to-machine) PLC communication. - TCP connection to any Server IP address:port number (e.g. to NIST Timer Server) - FTP upload of PLC's created data files to external FTP servers - Event-driven Emailing. Create and save data file on a networked PC's hard disk - Excel spreadsheet Data Logging using TRI-ExcellLink software	
	RS232 / RS485	Supported Protocols : Native ASCII Host Link Commands (programming/monitoring) MODBUS RTU, MODBUS ASCII, OMRON C20H Host Link Commands Default COM speed 38,400 bps, may be set from 1200 to 115.2K & 230.4K bps	
Memory Storage	- Program	23.5K words (16-bit) of program memory stored in flash memory.	
	- Data	A to Z (32-bit Integer), A\$ to Z\$ (ASCII strings) ² DM[1] to DM[4000] (16-bit integer array) A# to Z#, ² FP[1] to FP[1000] (32-bit floating point variables) 6K Words (16-bit) additional non-volatile ¹ FRAM memory for integer and string storage	
	- Flash File System	1740K bytes Flash Drive. Data Logging, storage of user's webpages or applet. Access by FTP	
Programming Lang. / Env.	iTRiLOGI Version 7 (Ladder Logic +Floating Point BASIC)		
Dimensions / Weight	- 7.05" (L) x 4.45" (W) x 1.5" (H) / 0.65 lbs (0.296 Kg)		
I/O Expansion (Digital)	Expandable to 128 D/I and 128 D/O using EXP4040 and EXP1616R.		

PLC Environmental Specs (Temperature and Vibration)

Operating Temperature	- Operating 0 to 70 deg C (32 to 158 deg F) - Storage -20 to +85 deg C (-4 to 185 deg F)
Operating Humidity	10% - 90% Rel. Humidity, non condensing
Electrical Noise Resistance	IEC801-4 (Fast transient) - 2KV to power supply, 50 microsecond pulse width, 1 min. 1KV to I/O by capacitive coupling, 50 microsecond pulse width.
Vibration resistance	IEC 68-2-6/1980 Vibration 1.6mm - 25Hz to 100Hz - Amplitude = +1. - Acceleration = + 4.0g

Absolute Max. Rating

Power Supply Input	30V
Digital Inputs	30V AC or DC
Digital Outputs	240V
Analog Channels (0 to 10V)	7V

¹FRAM: State-of-The-Art, Ferro Magnetic RAM. No battery required. Unlimited read/write cycles

²DM[] & FP[]: DM[1]-DM[4000] and FP[1]-FP[1000] are automatically backup in FRAM and are therefore non-volatile.

RoHS	Compliant
------	-----------